

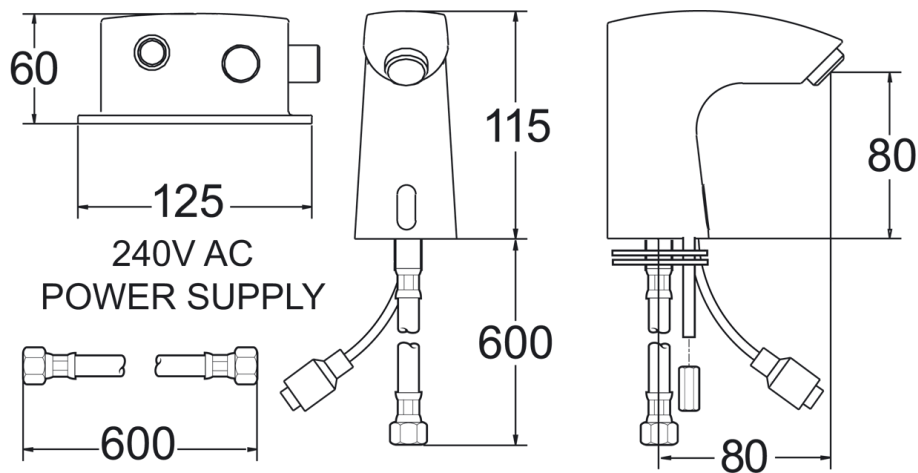

## SPECIFICATION SHEET



- Mains operated with battery back-up.
- Vandal and scratch resistant sensor window.
- Moisture and water resistant control unit.
- Suitable for cold or premixed water.
- Maximum operational temperature 45°C.
- Minimum pressure required 0.5bar.
- Choice of battery or mains power.
- Battery operation requires 4 x AA batteries.



|                     |            |
|---------------------|------------|
| <b>Manufacturer</b> | DEVA-UK    |
| <b>Finish</b>       | CHROME     |
| <b>Article code</b> | SENSOR 1/D |